

*FLEX-6500 & FLEX-6700 HF/50MHz Transceivers &
FLEX-6700R HF/VHF Receiver with SmartSDR™*

FLEX-6000

Signature Series

Changing Ham Radio — Forever...



Introducing the FLEX-6000™ Signature Series Transceivers with SmartSDR™

Imagine a transceiver that changes Ham Radio — forever...

FlexRadio Systems is changing the face of Ham Radio. It is not often that a team of smart people are allowed to start with a clean sheet of paper and dream. Imagine if we could take everything we have learned in amateur, commercial and government markets and build a new class of transceiver, virtually without limits. Imagine if digital radio capabilities previously affordable only for commercial and government applications were now cost effective for Ham transceivers. Imagine a radio that will be a platform for dream applications both today and in the future.

Imagine SmartSDR™

With the FLEX-6000 Signature Series radios, FlexRadio brings a wealth of new capabilities to the amateur including direct digital reception, transmission and networking. At the core of all these new capabilities is SmartSDR. SmartSDR organizes all of the signal processing power in the FLEX-6000 Signature Series radios into an advanced reusable framework. First, the RF subsystems in the FLEX-6000 are virtualized as reusable hardware blocks or Spectral Capture Units (SCU) with specific capabilities. SmartSDR understands the capabilities of each SCU and how to harness its power.

As data from the SCUs enters the Field Programmable Gate Array (FPGA) at a combined rate of over 7.8Gbps, SmartSDR performs advanced Digital Signal Processing (DSP) on the data, splitting it into individual Panadapters and Slice Receivers. Panadapters are visual displays of the RF spectrum akin to a spectrum analyzer, but with more capabilities for the amateur. Slice Receivers

are dynamically allocated full performance receivers that can be directed to the speaker or headphones for listening, or can be streamed as digitized RF to external digital applications. Panadapters and Slice Receivers can be created and destroyed at will.

What distinguishes SmartSDR is the simplification of these advanced concepts into an elegant graphical user interface (GUI) that places you in complete control. Want to create an additional Panadapter to watch for possible 10m band openings? No problem, simply click to add the Panadapter and SmartSDR directs everything from the advanced signal processing software down to the filters in the SCU to form an optimized receiver. Want to decode all of the CW signals on 40m while working DX on 20m? It's just a few clicks away. In the future, remote FLEX-6000 Signature Series radios will be equal partners in the SmartSDR ecosystem. Imagine the capabilities: Want to add two remote receivers so you never miss another check-in as Net Control? Just click to add and combine them.

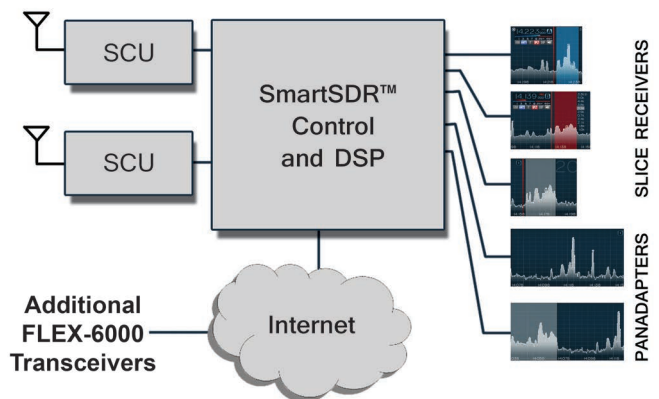

Imagine complex things made simple...

SmartSDR takes complex hardware and software and makes it elegant and simple to use. As smart phones and tablets have made computing devices accessible to the masses, the SmartSDR architecture truly delivers on the promise of a Software Defined Radio for the masses.

Just as FlexRadio set the standard for visual radio interaction, SmartSDR sets a new bar for visual radio display and control. Following the simple is better rule; we built a new graphical interface that is easy to learn and use. Multiple high-resolution, real-time spectral displays are at the heart of the SmartSDR experience. Intuitive controls are hidden from view to minimize clutter yet are instantly available when needed.

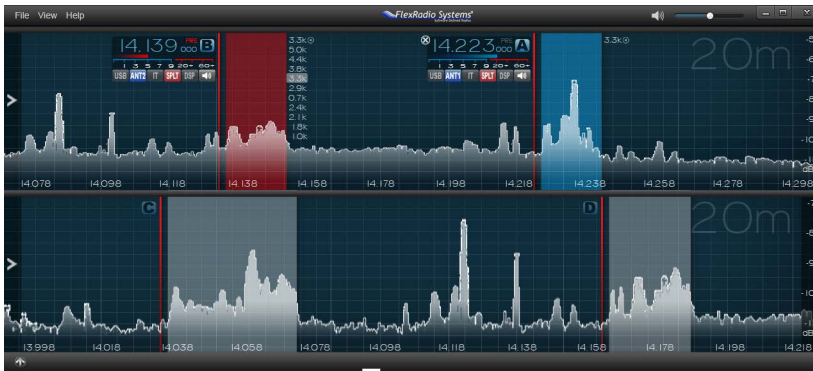

SmartSDR™ Graphical Interface

The FLEX-6000 Signature Series was designed with plug-and-play installation as a requirement. There are no drivers or interface cards to install. Just plug the radio into an antenna, power supply and network, load the SmartSDR software on your existing PC and operate.

Imagine networking as forethought, not afterthought...

Networking is at the heart of the new FLEX-6000 Signature Series radios. From across the shack or across the world, these new radios are designed with the latest networking capabilities.

Each FLEX-6000 Signature Series radio is equipped with a 1Gb Ethernet port for communication to existing PCs or other future display platforms. Initial software enables operation within the home network domain. Future releases will enable operation from any location in the world with an Internet connection. No external computer or expensive adapters are required at the radio site for remote operation.

What about sharing radios with your buddy, team or club? Future add on products will enable multi-user sharing of radio resources at the station and across the net. Imagine multi-multi contest and field day stations that allow dynamic allocation of slice

receivers from any workstation. Think of DX-peditions where isolated transmitters and receivers are connected to the operator's logging stations with only Ethernet cable. And club members will be able to share the club station from their living room or pool side.



Imagine digital starting at the antenna connector...

The FLEX-6000 Signature Series achieves the ultimate goal of RF to bits at the antenna connector. Digital Down Conversion (DDC) of the signal at RF, virtually eliminates the performance limitations inherent in legacy superheterodyne roofing filter based transceivers. Gone is the requirement for analog mixing and IF amplification stages that add images and intermodulation distortion. Eliminated is the need for expensive crystal roofing filters that add their own distortion and ringing. Direct digital receivers are simply quieter and less fatiguing to listen to over longer periods of time.

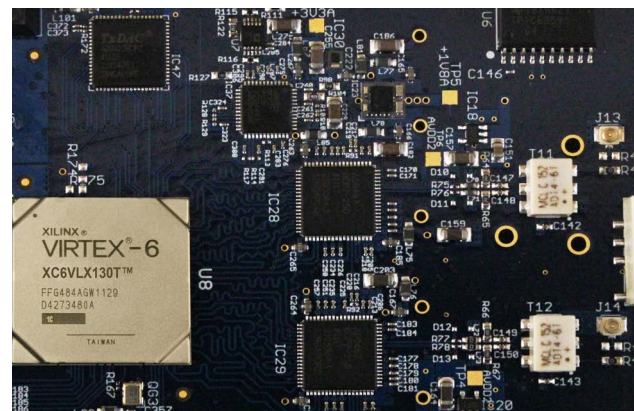

Since 100% of the receiver and transmitter mixing and filtering are done in the digital domain, unwanted sideband suppression, filter shaping, carrier suppression, and image rejection are no longer limited by non-linear analog circuits. Further, infinitely variable brick wall digital filters allow precise interference elimination without added distortion.

The FLEX-6700 and FLEX-6700R incorporate two independent, synchronous Analog Devices AD9467 16-bit 245.76 Msps (Mega samples per second) analog to digital converters (ADC) that allow direct digitization of the RF spectrum.

Each of the two Spectral Capture Units allows simultaneous reception from their own respective antenna or the two can be optimally combined to deliver increased dynamic range. In addition, dual SCUs provide the capability for diversity reception, beam steering, noise mitigation, and multi-antenna monitoring. The FLEX-6500 is equipped with a single Spectral Capture Unit.

Not only is reception all digital; so is transmission. The FLEX-6700 and FLEX-6500 transceivers incorporate an Analog Devices AD9122 16-bit digital to analog converter (DAC) operating at 491.52 Msps. Direct Digital Up Conversion (DUC) eliminates the traditional analog mixing and IF amplification, thus maximizing carrier and unwanted sideband suppression while minimizing spurious output and in-band intermodulation distortion.

Imagine up to 8 full performance receivers in one radio...

The FLEX-6700 transceiver and FLEX-6700R receiver each allow creation of up to 8 independent Slice Receivers providing reception from 0.03 MHz to 77 MHz and 135 MHz to 165 MHz. The FLEX-6500 allows creation of up to 4 Slice Receivers with tuning from 0.03 MHz to 77 MHz. Each Slice Receiver can provide independent spectral display of up to 384 kHz.

Slice Receivers allow you to simultaneously visually and audibly monitor multiple frequencies within the same band or multiple bands. SO2R stations can chase multiplier frequencies while holding down a run frequency using a single radio.

Now it is easy to watch for band openings across multiple bands from anywhere on the network. What about monitoring repeaters on 10m, 6m, and 2m at the same time? The possibilities are endless.

Imagine dynamic range so high it is no longer a limitation...

Direct RF to digital conversion allows the FLEX-6000 Signature Series to deliver up to +45 dBm IP3 (3rd Order Intercept Point) and 110 dB IMD DR3 (3rd Order Dynamic Range) *inside the final filter bandwidth*. This means that the FLEX-6000 Signature Series dynamic range is just as high at 100 Hz spacing as it is at 2 kHz spacing. This lets you work the pileups with ease and reduces auditory fatigue typically caused by in-band distortion in crystal filter based radios. Legacy multi-conversion, roofing filter architecture radios tend to “fold” and distort as the signal spacing is reduced near or inside the final filter bandwidth. That is why other manufacturers typically refer to dynamic range at wide tone spacing and some quote meaningless numbers without any reference at all.

As 3rd Order Dynamic Range is increased, Phase Noise Dynamic Range (PNDR) becomes the dominant performance specification. Legacy multi-conversion radios must use frequency synthesizers for tuning, which typically exhibit high close-in phase noise and spurious output. The FLEX-6000 Signature Series achieves world class PNDR through the incorporation of an ultra-low phase noise master oscillator operating at 983.04 MHz. Clock drivers in the FLEX-6000 deliver phase noise performance better than -130 dBc/Hz at 1 kHz offset, -147 dBc/Hz at 10 kHz offset and -152 dBc/Hz at 100 kHz offset. This results in the ability to hear weaker signals and provides a cleaner transmitted signal.

Except for the most demanding large signal conditions, Slice Receivers are free to operate in wide-band mode without the need for RF pre-selection filters. This maximizes receiver flexibility with

minimal impact to overall dynamic range. Optimally, when needed for increased out of band rejection, 10 Ham band, band-pass preselector banks are available on each Spectral Capture Unit. These filters incorporate mechanical relays and ceramic core inductors virtually eliminating distortion that can be caused by non-linear filter and switching components.

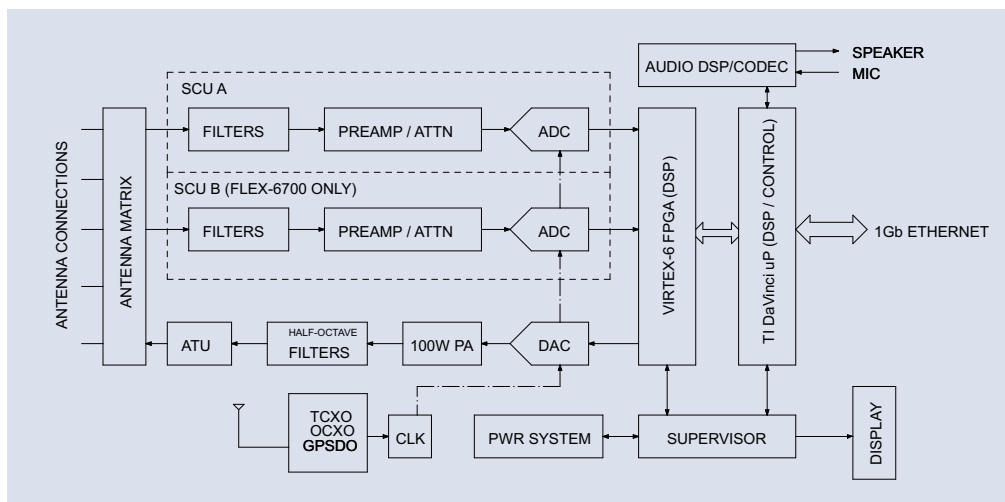





FLEX-6000 Signature Series Hardware Architecture

In all but the quietest rural locations, preamplifiers are not needed nor are they desired for typical HF operation. Since the FLEX-6000 Signature Series ADCs are internally buffered, they can be connected directly to the antenna thereby maximizing large signal handling capability and spurious free dynamic range. Further, the dual Spectral Capture Units can be optimally combined on the FLEX-6700 and FLEX-6700R to increase Blocking Dynamic Range up to 3 dB and IMD DR3 up to 2 dB.

When RF amplifiers are needed, all models incorporate an Analog Devices ADL5201 Digital Variable Gain Amplifiers (DVGA) for each Spectral Capture Unit that is optimal for HF through low VHF. The ADL5201 provides -11.5 dB to +20 dB of gain in 0.5 dB steps with a 7.5 dB noise figure and a typical output IP3 of up to +50 dBm at 50 MHz. The 31.5 dB range of the DVGA's digital input attenuator allows the system gain to be optimized for maximum dynamic range for the given band conditions. The FLEX-6700 and FLEX-6700R also include an Analog Devices ADL5534 +20 dB gain, 2.5 dB noise figure, +39 dB output IP3 RF amplifier. On these models the ADL5534 can be switched in series with the ADL5201 DVGA with an optimal attenuation setting to adjust the noise figure for operation in the 135 MHz to 165 MHz range.

Imagine digital signal processing power that enables the unimaginable...

The FLEX-6000 Signature Series packs more built-in digital signal process power than ever before imagined in an amateur radio transceiver. The FLEX-6700 and FLEX-6700R weighs in at a massive 317 billion multiply-accumulate operations per second (GMACs) and 121 billion floating point operations per second (GFLOPS). The FLEX-6500 delivers 191 GMACs and 78 GFLOPS. This level of performance allows the FLEX-6000 Signature Series to become a platform for amateur radio communication applications that were never before considered.

Brand A Texas Instruments TMS320VC33	0.120 GFLOPS	
Brand B Texas Instruments TMS320C6713 x3 + TMS320C6711	4.95 GFLOPS 1.35 GMAC	
Brand C Texas Instruments TMS320C6727B x2	4.2 GFLOPS 1.40 GMAC	
FLEX-6500 Texas Instruments TMS320DM8168 + XC6VLX75T	78 GFLOPS 191 GMAC	
FLEX-6700 / FLEX-6700R Texas Instruments TMS320DM8168 + XC6VLX130T	121 GFLOPS 317 GMAC	

Transceiver DSP Performance Comparison

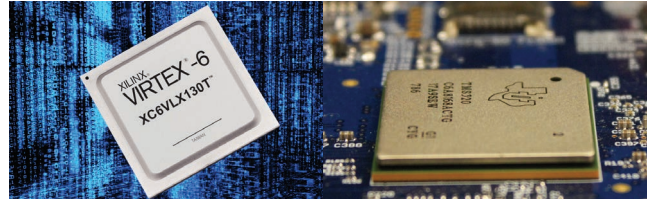

The FLEX-6000 Signature Series incorporates a Xilinx® Virtex®-6 field programmable gate array (FPGA) that performs all digital up and down conversion as well as spectral analysis. The FPGA works in tandem with a Texas Instruments™ DaVinci™ Digital Media Processor that includes a 1.4 GHz (1.2 GHz on FLEX-6500) ARM Cortex™-A8 CPU with NEON™ floating point coprocessor. It also includes a 1.2 GHz (1.0 GHz on FLEX-6500), 32-bit floating point DSP coprocessor. The CPU incorporates 512 MB of 1333 MHz DDR3 RAM, 1 Gbps Ethernet port and two USB 2.0 communication ports.

The DaVinci processor performs final digital signal processing, Ethernet data communications, and radio control functions. In addition, the radios incorporate two programmable system on a chip processors for system management and control.

Imagine all digital QSK CW in hardware...

The FLEX-6500 and FLEX-6700 transceivers utilize FPGA hardware to directly generate the CW waveform digitally at the RF carrier frequency. This means that the RF carrier switches at hardware speeds without first element truncation as is typical in many radios. When combined high speed TR and bias switching on the PA, <10 millisecond key down to RF output is achieved. True FSK mark/space carrier is also digitally generated directly at the RF output frequency.

Imagine FlexRadio's Famous Audio Quality...

FlexRadio's reputation for amazing quality audio continues and is further enhanced with the FLEX-6000 Signature Series. Direct digital up conversion and pure digital filtering virtually eliminate transmit audio distortion. The FLEX-6700 and FLEX-6500 incorporate a dedicated streaming audio DSP for low latency parametric equalization, RF audio compression, automatic level control, noise gating, and monitoring. Transmit audio bandwidth is continuously adjustable up to 10 kHz for AM and Enhanced Single Sideband Modes.

Imagine a RF power amplifier that goes beyond the norm...

A SmartSDR deserves a high performance RF power amplifier system designed to match. The FLEX-6500 and FLEX-6700 incorporate a push-pull pair of rugged RD100HHF1 MOSFET transistors operating at 13.8V DC. The FLEX-6500 and FLEX-6700 both include an automatic antenna tuner capable of tuning antennas over 10:1 range (3:1 on 160m and 6m). Both models provide an unprecedented 11 half-octave low pass filter banks to allow continuous coverage for MARS operation. Two 80mm quiet, temperature controlled fans pressurize the enclosure to force air through the PA heat sink fins and out through the back panel.

The PA subsystem is controlled by a dedicated Programmable System on Chip processor that provides all thermal management, intelligent bias control, power/SWR monitoring, antenna impedance measurement, T/R switching, antenna tuning, and relay control.

Power and real time SWR measurement is provided by a Tandem Match directional coupler in conjunction with an Analog Devices ADL5519 Dual Log Power Detector. This forms a precision measurement instrument with bridge directivity >30 dB from 80m through 6m (21 dB on 160m). Unlike the conventional diode detectors used by other manufacturers, the log detector provides

>50 dB power measurement range with +1 dB linearity and >40 dB range with much better than ± 0.25 dB linearity. The ADL5519 also provides hardware return loss calculation to allow real time SWR display on modulated signals.

Imagine frequency control locked to the GPS system...

The FLEX-6000 Signature Series is the first amateur radio product family to offer an optional built-in GPS Disciplined Oscillator (GPSDO). The GPSDO plug in module provides a precision 10 MHz reference for the 983.04 MHz master oscillator and to a rear panel 10 MHz SMA output connector for external precision frequency control. Frequency stability is 1×10^{-8} within 5 minutes at 25° C and 5×10^{-12} over 24 hours with GPS lock. Rear panel SMA connections are provided for the GPS antenna input and 10MHz reference output.

When the GPSDO option is not installed, the FLEX-6700 and FLEX-6700R come standard with a ± 0.02 ppm Oven Controlled Crystal Oscillator (OCXO) and the FLEX-6500 comes with at ± 0.5 ppm Temperature Controlled Crystal Oscillator (TCXO).

5

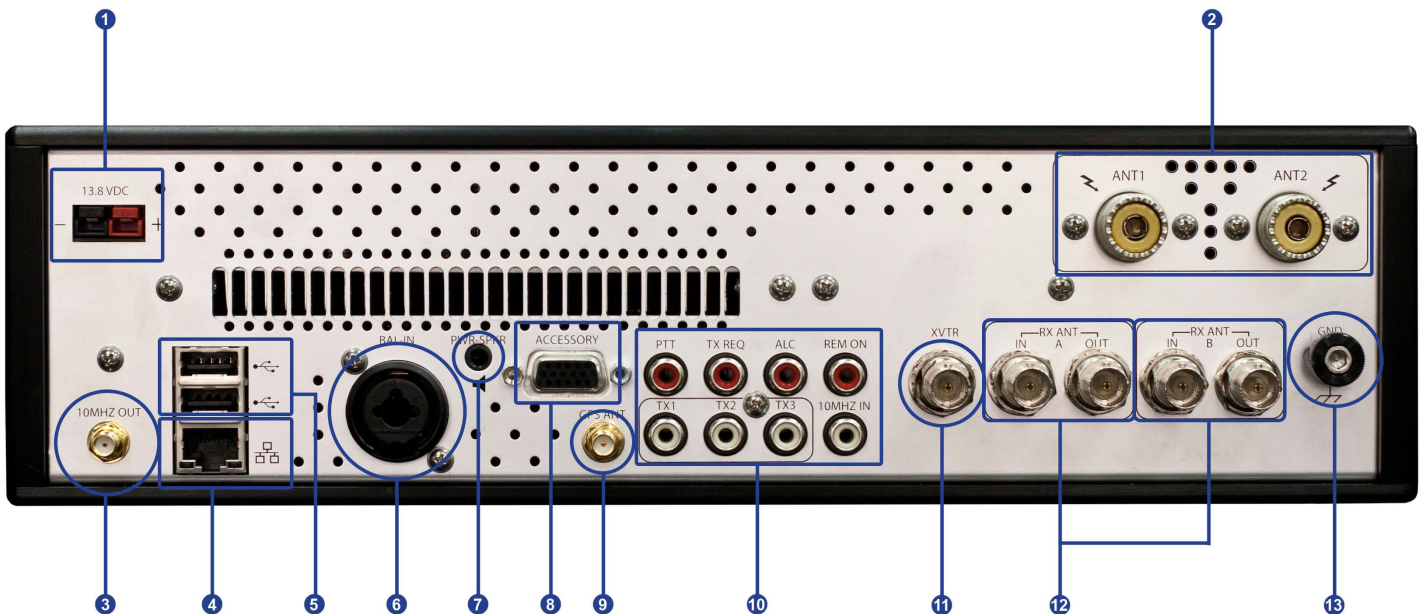

- 1 +13.8V DC Power In
- 2 Antenna Connectors
- 3 Optional 10 MHz GPSDO Output
- 4 1 Gb Ethernet Connector
- 5 USB 2.0 Peripheral Connections
- 6 Balanced Microphone/Line Input
- 7 Powered Speaker/Line Output
- 8 Accessory Connector
- 9 Optional GPS Antenna Input
- 10 TX Relay Control
- 11 Transverter IF Connector
- 12 SCU Receive Antenna Connectors
- 13 Ground Terminal

FLEX-6700 Signature Series Rear Panel Depiction

PRELIMINARY SPECIFICATIONS¹

	FLEX-6500 Transceiver	FLEX-6700 Transceiver	FLEX-6700R Receiver
GENERAL			
Central Processing Unit & DSP	TMS320DM8168CYG2	TMS320DM8168CYG4	TMS320DM8168CYG4
RISC Processor	1.2 GHz ARM Cortex™-A8/NEON™	1.4 GHz ARM Cortex™-A8/NEON™	1.4 GHz ARM Cortex™-A8/NEON™
DSP Coprocessor	1.0 GHz TMS320C647x 32-bit FP	1.2 GHz TMS320C647x 32-bit FP	1.2 GHz TMS320C647x 32-bit FP
RAM Memory	512 MB 1.333 GHz DDR3	512 MB 1.333 GHz DDR3	512 MB 1.333 GHz DDR3
Field Programmable Gate Array (FPGA)	Xilinx XC6VLX75T	Xilinx XC6VLX130T	Xilinx XC6VLX130T
DSP Multiply Accumulate Performance ²	191 GMAC	317 GMAC	317 GMAC
DSP Floating Point Operations	78 GFLOPS	121 GFLOPS	121 GFLOPS
Ethernet Communications	1 Gbps	1 Gbps	1 Gbps
USB 2.0 Ports (peripheral control)	2	2	2
Master Clock Frequency	983.04 MHz	983.04 MHz	983.04 MHz
Master Clock Phase Noise in dBc/Hz @ 245.76 MHz	-147 dBc @ 10 kHz, -152 dBc @ 100 kHz	-147 dBc @ 10 kHz, -152 dBc @ 100 kHz	-147 dBc @ 10 kHz, -152 dBc @ 100 kHz
10 MHz Reference Clock Stability (0 to +50° C; +32 to +122°F)	0.5ppm TCXO	0.02ppm OCXO	0.02ppm OCXO
GPSTCXO With Rear Panel 10MHz Reference Output	Optional	Optional	Optional
GPSTCXO Frequency Stability (GPS locked)	5x10 ⁻¹² over 24 hours	5x10 ⁻¹² over 24 hours	5x10 ⁻¹² over 24 hours
Modes	USB, LSB, CW, RTTY, AM, FM	USB, LSB, CW, RTTY, AM, FM	USB, LSB, CW, RTTY, AM, FM
Frequency Resolution	1 Hz min.	1 Hz min.	1 Hz min.
Number of Memory Channels	Unlimited	Unlimited	Unlimited
Antenna Connectors	SO-239x2; BNCx1; XVTRx1	SO-239x2; BNCx2; XVTRx1	BNCx2
Antenna Impedance (without tuner)	50 Ohm Unbalanced	50 Ohm Unbalanced	50 Ohm Unbalanced
Power Supply Requirements	+13.8V DC ±15%	+13.8V DC ±15%	25–264 VAC; 47–63Hz; 20W
Current Drain (Receive/Max. Power)	1.5A / 23A	1.5A / 23A	
Dimensions (with/without feet - 2U Rack Height)	13"W x 12" D x 4" H (2U - 3 1/2 in. without feet); 33cm x 30.5cm x 10.2cm (8.9cm w/o feet)	13"W x 12" D x 4" H (2U - 3 1/2 in. without feet); 33cm x 30.5cm x 10.2cm (8.9cm w/o feet)	13"W x 12" D x 4" H (2U - 3 1/2 in. without feet); 33cm x 30.5cm x 10.2cm (8.9cm w/o feet)
2U, 19 Inch (48.26cm) Rack Mounting Kit	Optional	Optional	Optional
Front Handle Kit (Adds 1 Inch/2.54cm to total depth)	Optional	Optional	Optional
Weight (approximate)	13lb; 5.9kg	13lb; 5.9kg	13lb; 5.9kg
Operating Temperature Range	0 to +50° C; +32 to +122°F	0 to +50° C; +32 to +122°F	0 to +50° C; +32 to +122°F
RECEIVER			
Receiver Architecture	Direct Digital Sampling	Direct Digital Sampling	Direct Digital Sampling
Spectral Capture Units	1	2	2
Maximum Slice Receivers	4	8	8
ADC Resolution	16-bits	16-bits	16-bits
ADC Sampling Rate	245.76 Msps	245.76 Msps	245.76 Msps
Wideband Frequency Coverage	30 kHz – 77 MHz	30 kHz – 77 MHz; 135 – 165 MHz	30 kHz – 77 MHz; 135 – 165 MHz
MDS - Minimum Discernible Signal (500 Hz Bandwidth — Preselector Off)	TBD	TBD	TBD
Amateur Band Preselector Coverage	160m – 6m (except 60m)	160m – 6m (except 60m)	160m – 6m (except 60m)
Preamplifiers/Attenuators	Preamp: -11.5 to +20 dB DVGA	PRE1: -11.5 to +20 dB DVGA; PRE2: 20 dB	PRE1: -11.5 to +20 dB DVGA; PRE2: 20 dB
Spurious and Image Rejection Ratio	100 dB or better	100 dB or better	100 dB or better
Internal Speaker Audio Output Power	1W diagnostic speaker	1W diagnostic speaker	1W diagnostic speaker
External Powered Speaker Output Impedance/Level	10kΩ min./2.6Vpp max.	10kΩ min./2.6Vpp max.	10kΩ min./2.6Vpp max.
TRANSMITTER			
Transmitter Architecture	Direct Digital Upconversion	Direct Digital Upconversion	NA
TX DAC Resolution	16-bits	16-bits	NA
TX DAC Sampling Rate	491.52 Msps	491.52 Msps	NA
RF Output Power	1-100W SSB, CW, FM, RTTY, DIGITAL; 1-30W AM	1-100W SSB, CW, FM, RTTY, DIGITAL; 1-30W AM	NA
Amateur Band Coverage at Rated Power Output	160m – 6m	160m – 6m	NA
Low Pass PA Filter Bands	11 half-octave	11 half-octave	NA
Transverter IF Output Power	+0dBm Typical, +10 dBm max.	+0dBm Typical, +10 dBm max.	NA
Transverter IF Frequency Coverage	100 kHz to 77 MHz	100 kHz to 77 MHz and 135 MHz to 165 MHz	NA
Modulation System	Digital Low Power at Carrier Frequency	Digital Low Power at Carrier Frequency	NA
Maximum FM Deviation	5 kHz	5 kHz	NA
Carrier Suppression	<-80 dBc typ.	<-80 dBc typ.	NA
Unwanted Sideband Suppression	<-80 dBc typ.	<-80 dBc typ.	NA
Harmonic Radiation 1.8 - 50 MHz Amateur Bands	<-60 dBc; -70dBc 6m	<-60 dBc; -70dBc 6m	NA
Transmit Bandwidth	Default 300-2700 Hz (Variable 50-10000 Hz)	Default 300-2700 Hz (Variable 50-10000 Hz)	NA
Microphone Connectors	Unbalanced 8-pin, Balanced XLR/TRS	Unbalanced 8-pin, Balanced XLR/TRS	NA
Microphone Impedance	600 Ohms Nominal (200-10kΩ)	600 Ohms Nominal (200-10kΩ)	NA
ANTENNA TUNER			
Matching Range 80m – 10m	5 Ohms – 500 Ohms	5 Ohms – 500 Ohms	NA
Matching Range 160m, 6m	16.7 Ohms – 150 Ohms	16.7 Ohms – 150 Ohms	NA

¹All specifications are subject to change without notice. Specifications guaranteed for amateur bands only.

²Based on 18x25 multiplier



4616 W. Howard Lane, Ste. 1-150
Austin, TX 78728
512-535-4713 (ph), 512-233-5143 (fax)
sales@flexradio.com
www.flexradio.com